

## TVN 0402 01 AB1 Engineering Specification

### 1 Scope

TVN 0402 01 AB1 is a TVS diode designed to protect one power/control line or one low speed signal line from overvoltage hazard of Electrostatic Discharge (**ESD**).

These interfaces can be used in computer interfaces protection, microprocessors protection, serial and parallel ports protection, control signal lines protection, power lines on PCB protection, latchup protection, etc. The ESD protection of TVS meets the immunity standard of IEC 61000-4-2, level 4 ( $\pm 8\text{kV}$  contact discharge).

### 2 Explanation of Part Number

TV    N    0402    01    AB1  
 (1)    (2)    (3)    (4)    (5)

- (1) Product Type : TV=TVS Diode
- (2) Capacitance Code : N=Normal Capacitance
- (3) Package Size Code
- (4) Channel Code : 01=1 Channels
- (5) Specialized Specification Code

### 3 . Circuit Diagram & Dimension

End termination : Ag/Ni/Sn

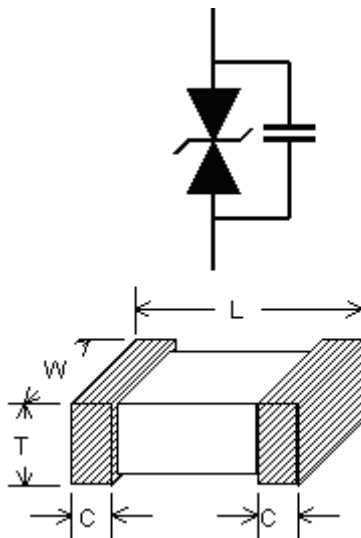

Unit: mm	0402
L	1.10±0.10
W	0.50±0.10
T	0.50±0.10
C	0.25±0.15

## 4 Specifications

### 4.1 ABSOLUTE MAXIMUM RATINGS

PARAMETER	PARAMETER	RATING	UNITS
Operating Supply Voltage	$V_{DC}$	5	V
ESD per IEC 61000-4-2 (Contact)	$V_{ESD}$	$\pm 8$	kV
Operating Temperature Range	$T_{OP}$	-45 to +125	$^{\circ}C$
Storage Temperature Range	$T_{STO}$	-50 to +150	$^{\circ}C$
Lead Soldering Temperature	$T_{SOL}$	260 (10 sec.)	$^{\circ}C$

### 4.2 ELECTRICAL CHARACTERISTICS

ELECTRICAL CHARACTERISTICS						
PARAMETER	SYMBOL	CONDITIONS	MINI	TYP	MAX	UNITS
Reverse Stand-Off Voltage	$V_{RWM}$	$T=25^{\circ}C$ .			5	V
Reverse Leakage Current	$I_{Leak}$	$V_{RWM} = 5V, T=25^{\circ}C$ .		1	2	$\mu A$
Reverse Breakdown Voltage	$V_{BV}$	$I_{BV} = 1mA, T=25^{\circ}C$ .		10		V
Clamping Voltage	$V_{CL}$	$I_{PP}=1A, t_p=8/20\mu s, T=25^{\circ}C$ .		12	14	V
Diode Capacitance	$C_p$	$V_R = 0V, f = 1MHz, T=25^{\circ}C$ .		50		pF

### 4.3 TYPICAL CHARACTERISTICS

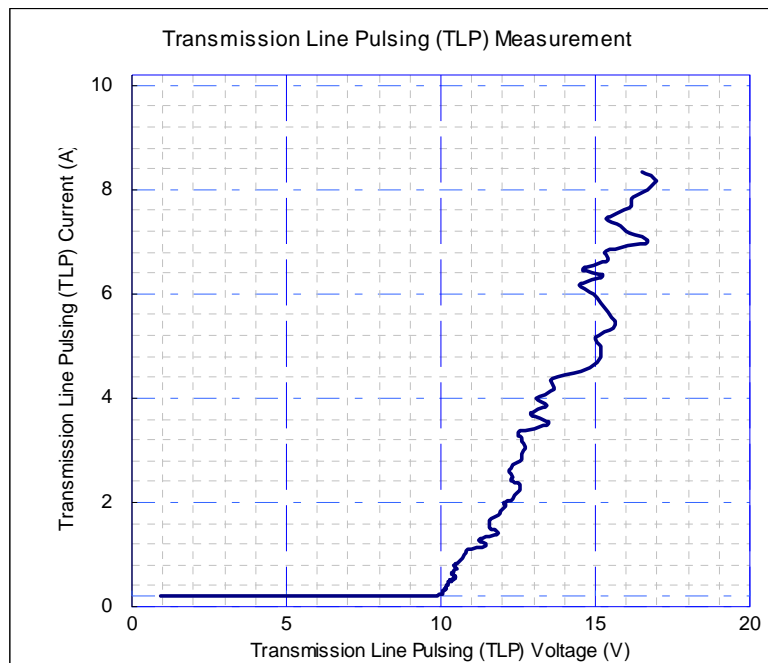

## 5 Taping Package and Label Marking

### 5.1 Packaging method

Products shall be heat-sealed in the chip pocket, spacing pitch 4-mm of plastic carrier tape with cover tape, and the carrier tape shall be reeled to the reel.

### 5.2 Carrier tape dimensions

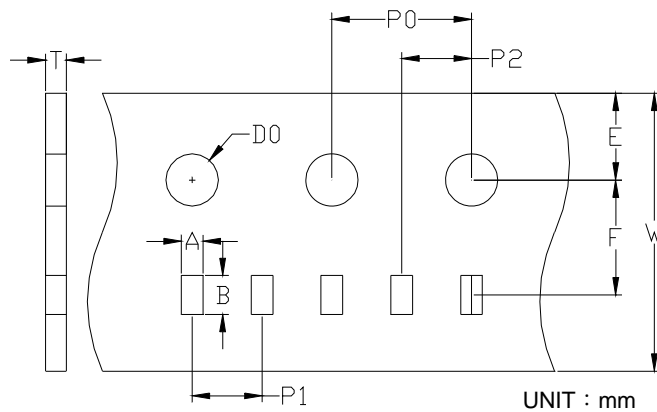

UNIT : mm

Type	A	B	W	E	F	P0	P1	P2	D0	T
0402	0.58 ±0.03	1.3 ±0.03	8.0 ±0.1	1.75 ±0.05	3.5 ±0.05	4.0 ±0.1	2.0 ±0.05	2.0 ±0.05	1.55 ±0.05	0.60 ±0.03

### 5.3 Taping reel dimensions

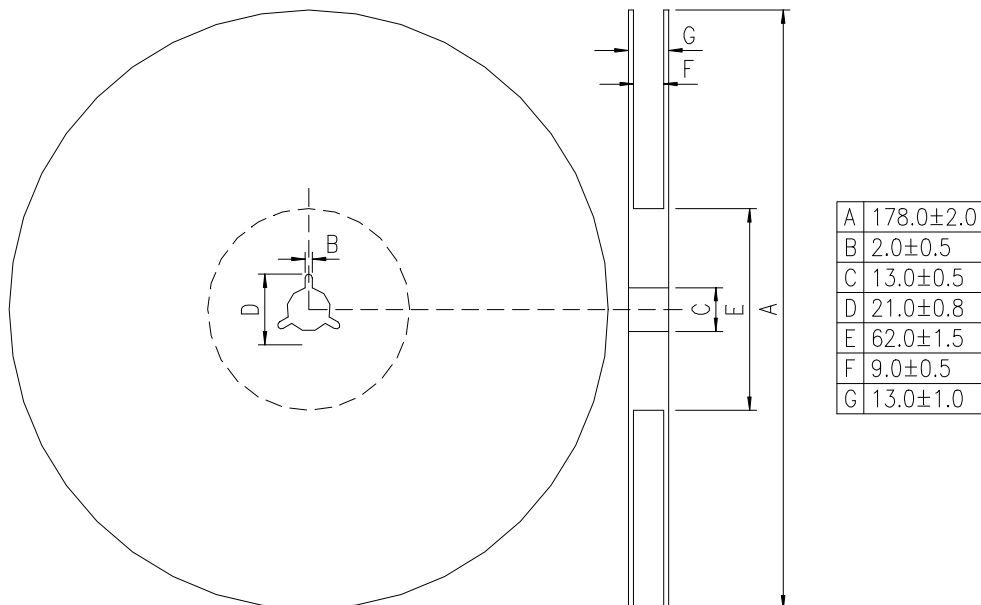

## 5.4 Taping specifications

There shall be the portion having no product in both the head and the end of taping, and there shall be the cover tape in the head of taping.

## 5.5 Label Marking

The label specified as follows shall be put on the side of reel.

- (1) Part No.
- (2) Quantity
- (3) Lot No.

\*Part No. And Quantity shall be marked on outer packaging.

## 5.6 Quantity of products in the taping package

- (1) Standard quantity : 10,000pcs/Reel for TVL0402 Series
- (2) Shipping quantity is a multiple of standard quantity.

## 6. Precautions for Handling

### 6.1 Solder cream in reflow soldering

Refer to the recommendable land pattern as printing mask pattern for solder cream.

- (1) Print solder in a thickness of 150 to 200  $\mu\text{m}$ .
- (2) Dimensions: millimeters (inches)

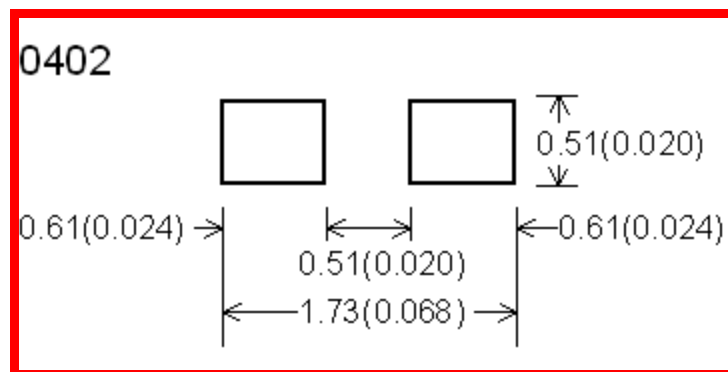

### 6.2 Precaution for handling of substrate

Do not exceed to bend the board after soldering this product extremely.

(Reference examples)

- Mounting place must be as far as possible from the position, which is close to the break line of board, or on the line of large holes of board.
- Do not bend extremely the board, in mounting another components.  
If necessary, use back-up pin (support pin) to prevent from bending extremely.
- Do not break the board by hand. We recommend using the machine or the jig to break it.

### 6.3 Precaution for soldering

Note that rapid heating, rapid cooling or local heating will easily damage this product. Do not give heat shock over 100°C in the process of soldering. We recommend taking preheating and gradual cooling.

### 6.4 Recommendable reflow soldering

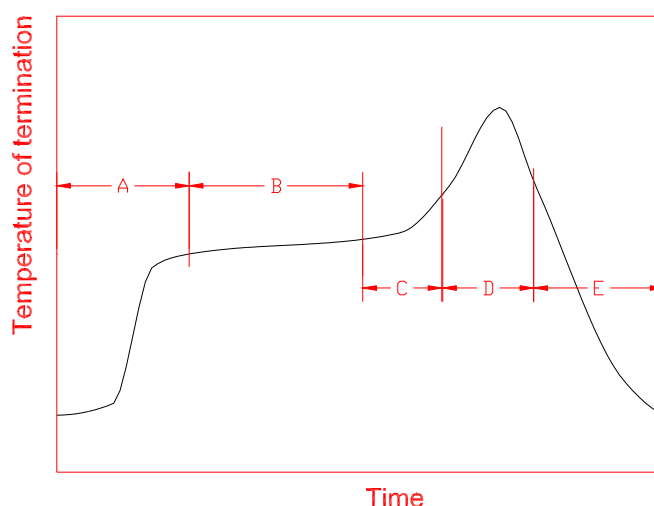

A	1 <sup>st</sup> rising temperature	The normal to Preheating temperature	30s to 60s
B	Preheating	140°C to 160°C	60s to 120s
C	2 <sup>nd</sup> rising temperature	Preheating to 200°C	20s to 40s
D	Main heating	if 220°C if 230°C if 240°C if 250°C if 260°C	50s~60s 40s~50s 30s~40s 20s~40s 20s~40s
E	Regular cooling	200°C to 100°C	1°C/s ~ 4°C/s

\*According to J-STD-020C

### 6.5 Soldering gun procedure

Note the follows, in case of using solder gun for replacement.

- (1) The tip temperature must be less than 280°C for the period within 3 seconds by using soldering gun less than 30 W.
- (2) The soldering gun tip shall not touch this product directly.

### 6.6 Soldering volume

Note that excess of soldering volume will easily get crack the body of this product.